

FALCON 121

Double Track

Reach diagram - Optimized position

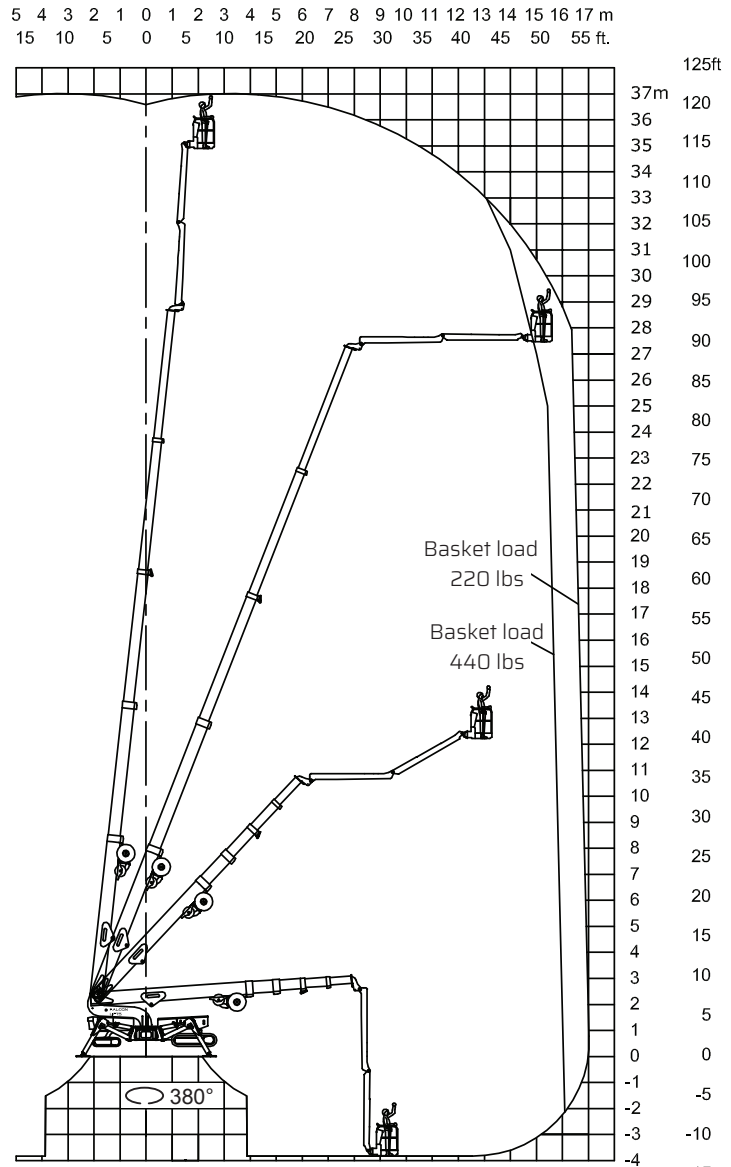
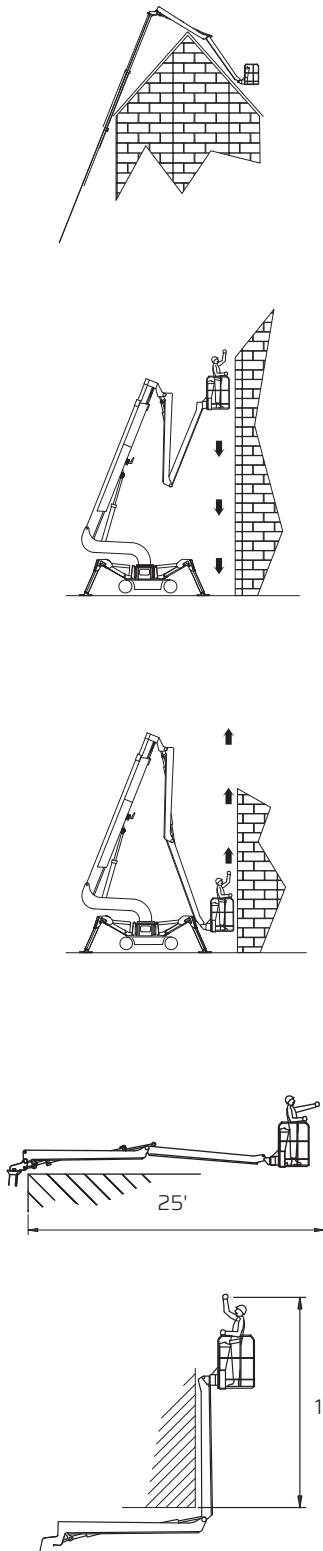

Reach with outriggers in different positions

Standard

Measurements in feet

Optimized

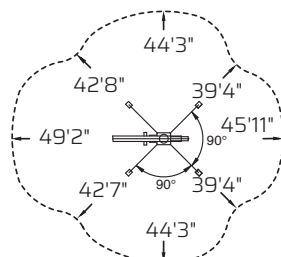

Basket load = 440 lbs

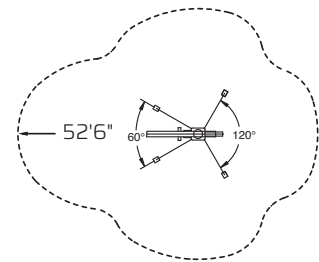

Basket load = 220 lbs

FALCON 121

Double Track

Outer measurements

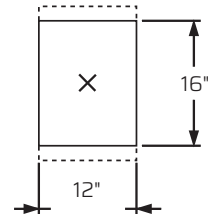
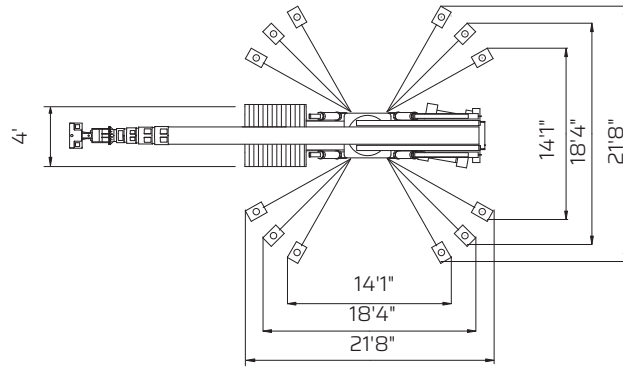
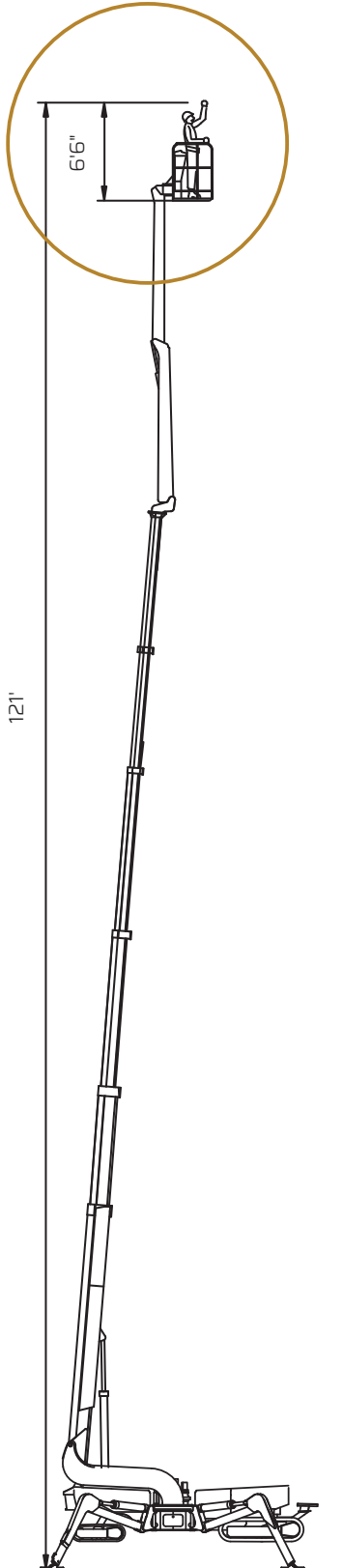

Outrigger plate area
 = 186 in²

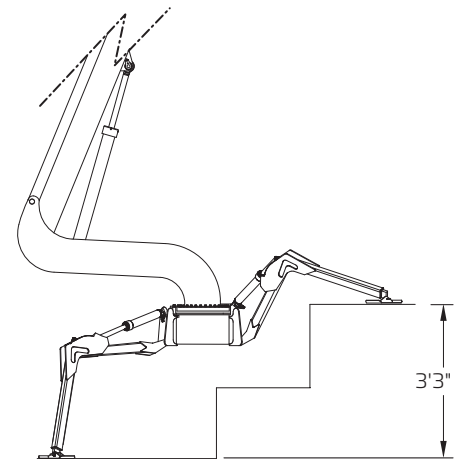
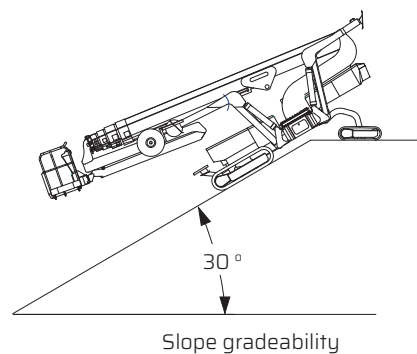
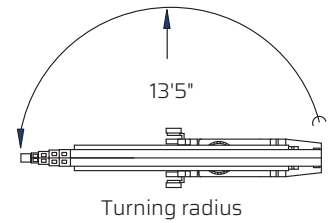
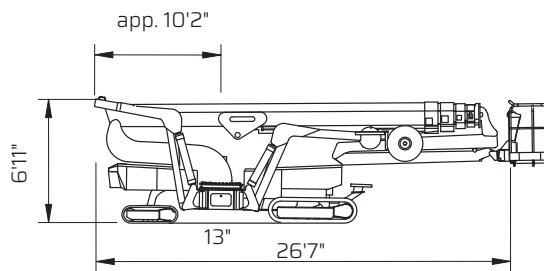

Additional info:

Weight and ground pressure:

Weight with standard equipment	16,535	lbs
Surface pressure under crawlers (soft surface)	11,4	PSI
Surface pressure under crawlers (hard surface)	22,7	PSI
Max. ground pressure under 1 outrigger plate	39,2	PSI