

FALCON 125XL *Vario*

Reach diagram - Optimized position

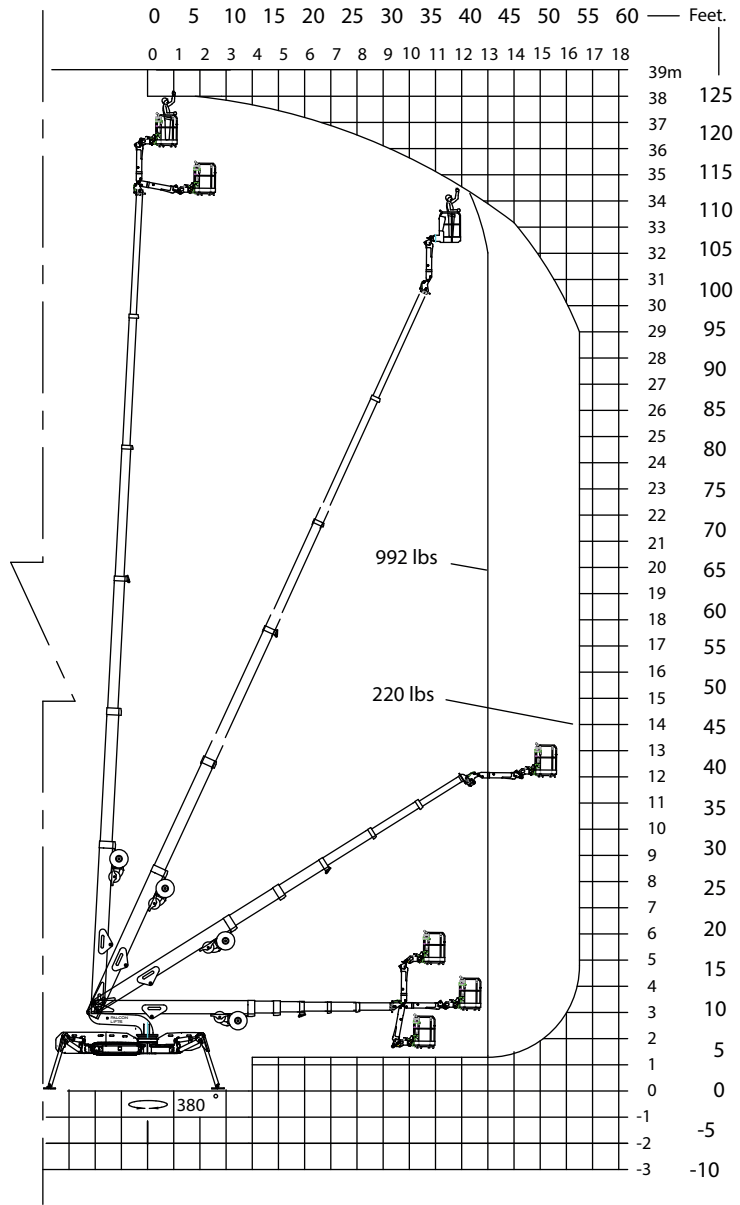
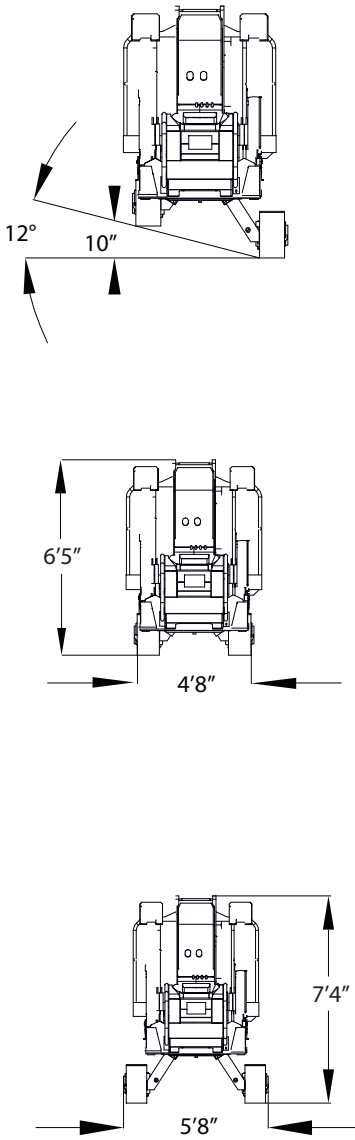

Reach with outriggers in different positions

Standard and Optimized

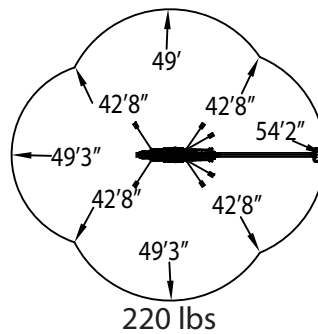
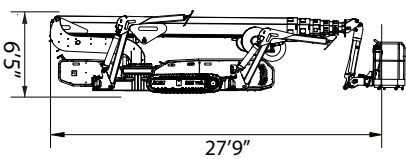

Basket load

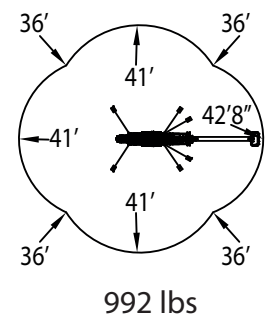

FALCON 125XL *Vario*

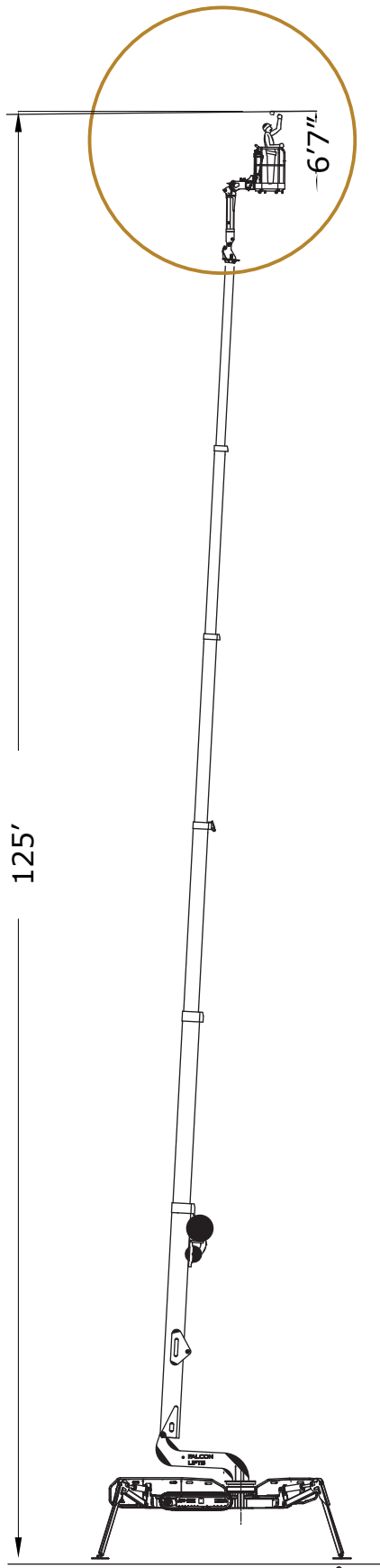

Outer measurements

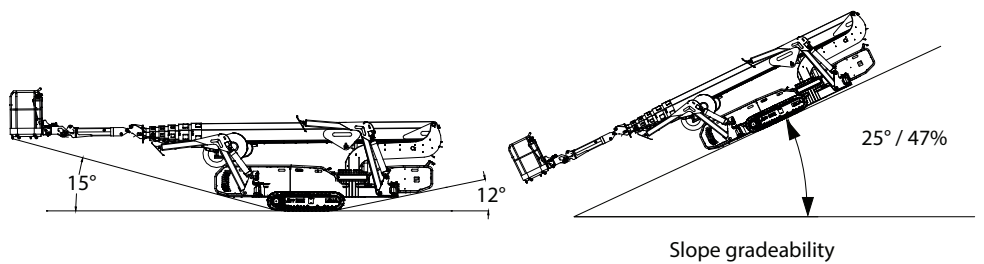
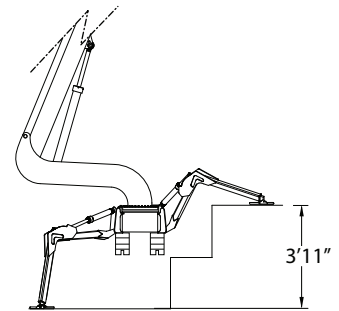
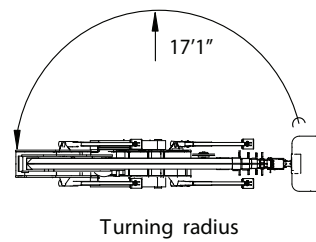
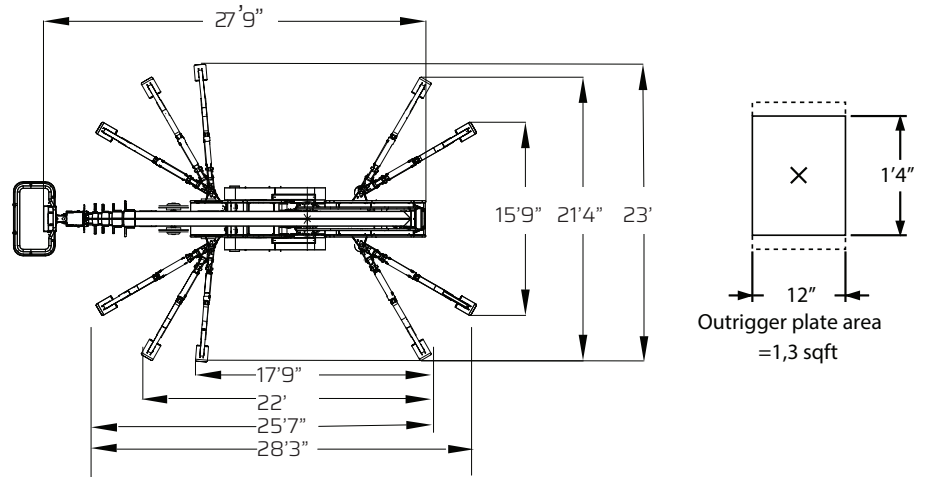

Additional info:

Weight and ground pressure:

Weight with standard equipment	18183	lbs
Surface pressure under crawlers (soft surface)	13.09	psi
Surface pressure under crawlers (hard surface)	26.17	psi
Max. ground pressure under 1 outrigger plate	48.64	psi