

# FALCON 138

*Double Track*

## Reach diagram - Optimized position

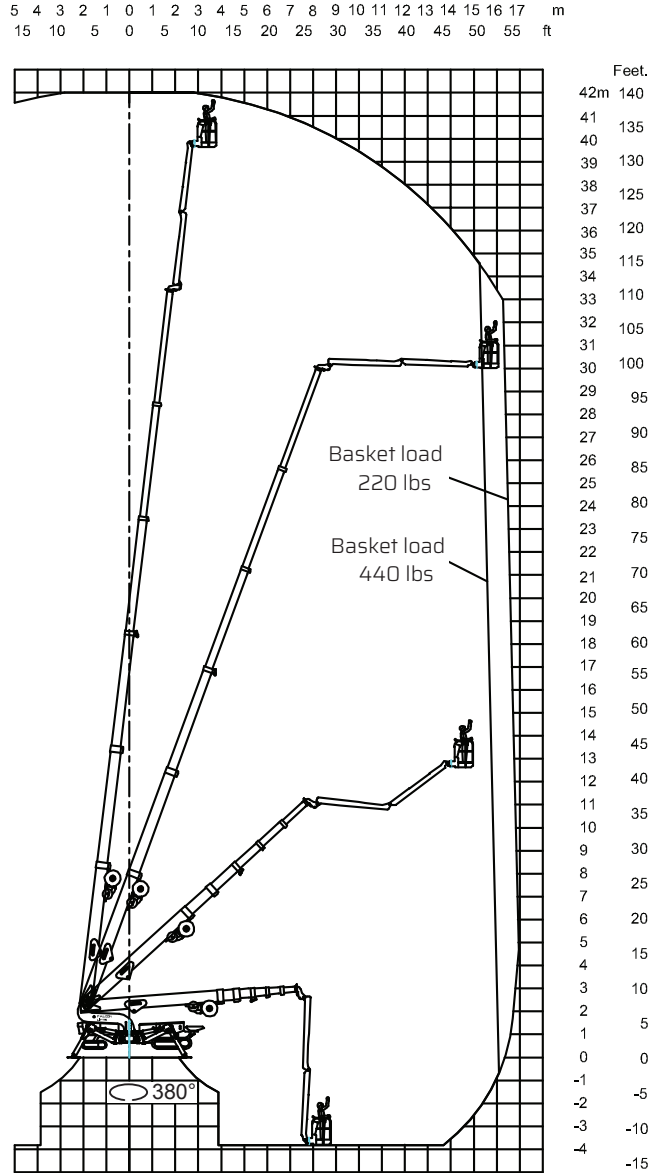
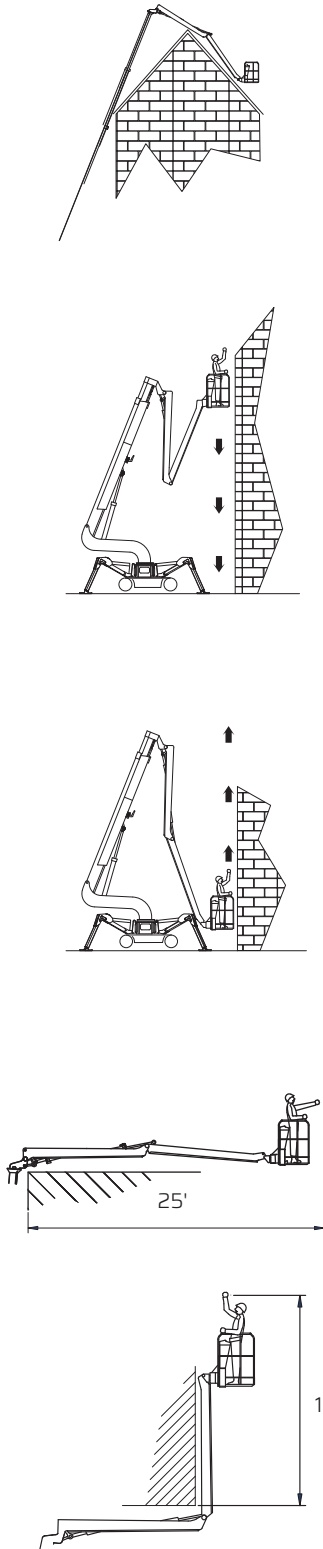

## Reach with outriggers in different positions

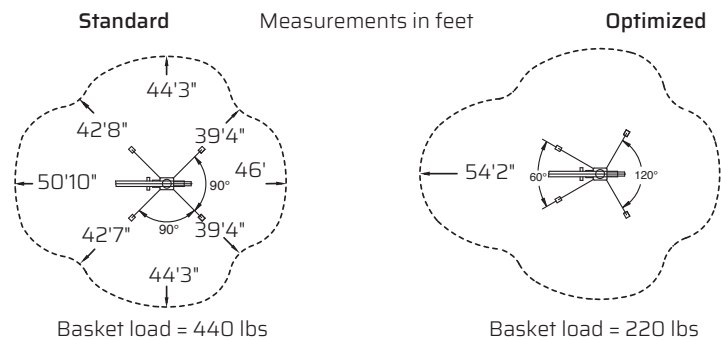

# FALCON 138

## Double Track

### Outer measurements

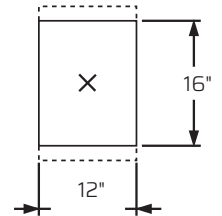
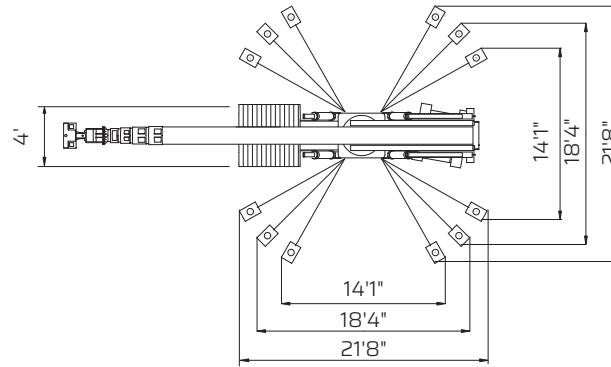
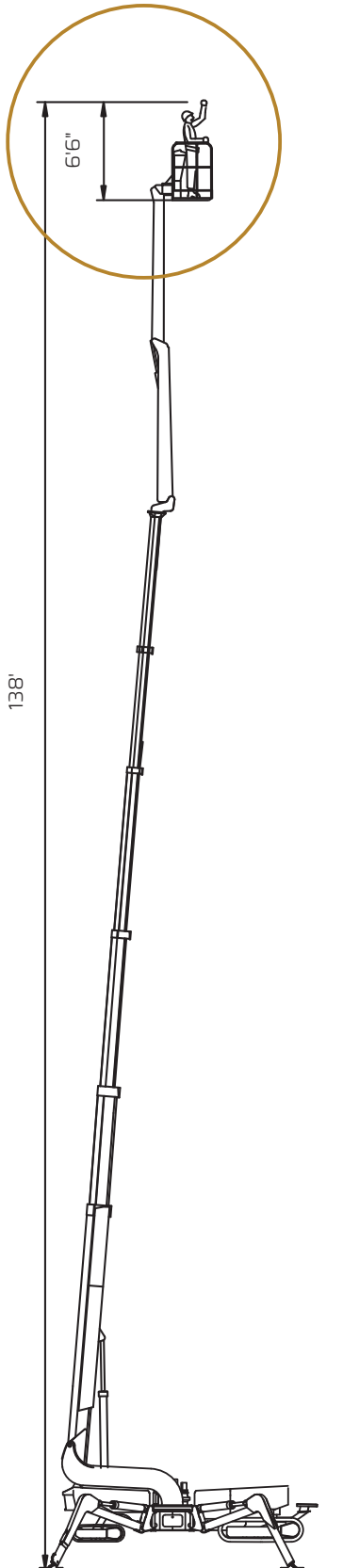

Outrigger plate area  
= 186 in<sup>2</sup>

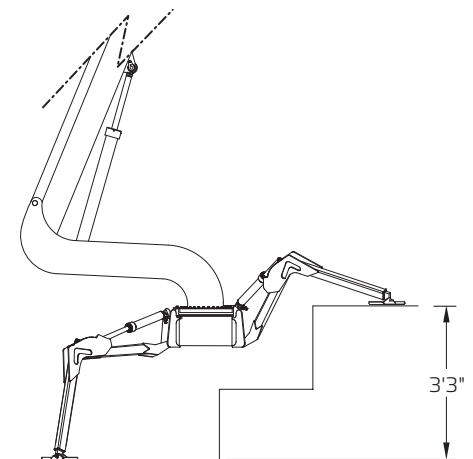
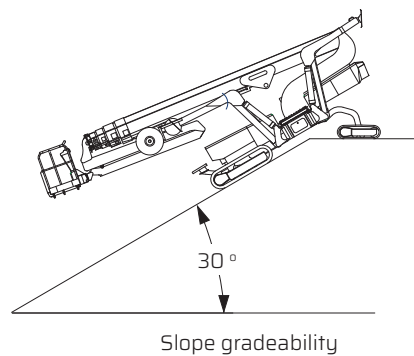
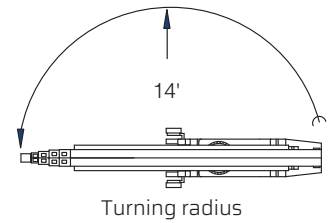
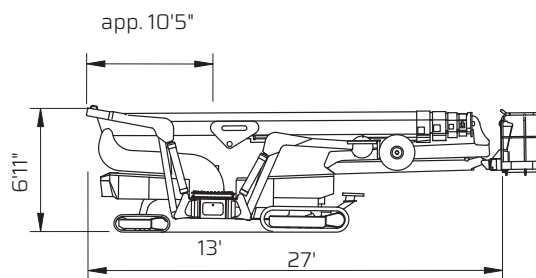

### Additional info:

#### Weight and ground pressure:

Weight with standard equipment	18075	lbs
Surface pressure under crawlers (soft surface)	12	PSI
Surface pressure under crawlers (hard surface)	24	PSI
Max. ground pressure under 1 outrigger plate	44	PSI